

Art.Code	L (mm)	Ls (mm)	K (mm)	D (mm)	H (mm)	B (mm)	M (mm)	d (mm)	Shore A
6002003443	184	150	126	175	63	184	M20i	13	40°
6002003457	184	150	126	175	63	184	M20i	13	55°
6002003468	184	150	126	175	63	184	M20i	13	70°

Indien gewenst is de machinevoet leverbaar met hoogteverstelling

- L = lengte
- Ls = hartafstand bevestigingsgaten
- K = diameter kap
- D = diameter
- H = hoogte
- B = breedte
- M = schroefdraad
- d = boring
- Shore A = hardheid

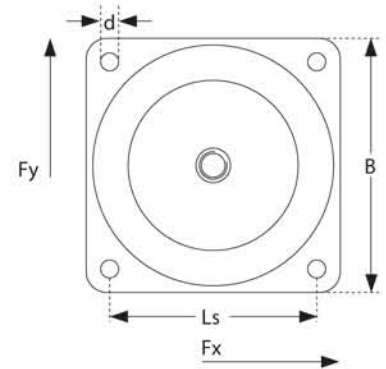
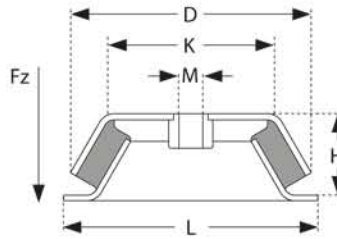

Belasting Fz

